

FLATWORK FINISHING EQUIPMENT

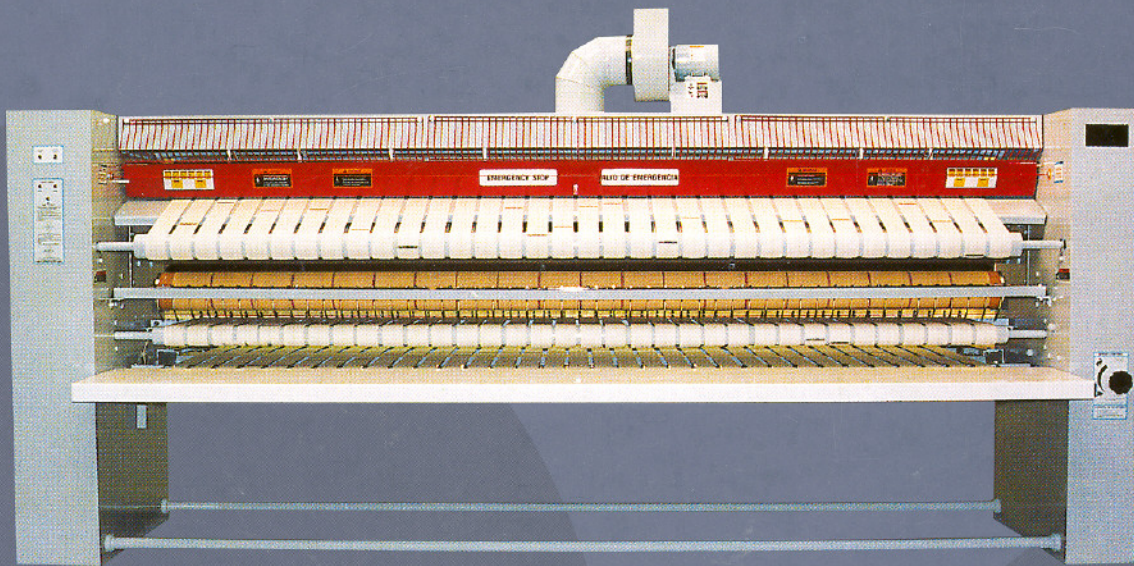

FLATWORK FINISHING EQUIPMENT

## SHARPER FINISH



FLATWORK FINISHING EQUIPMENT

FLATWORK FINISHING EQUIPMENT

## FINISH MASTER 2000

FLATWORK FINISHING EQUIPMENT

# FINISH MASTER **2000**

FLATWORK FINISHER

with Built-In AccuFold<sup>®</sup> Automatic Folder

The perfect combination to UPGRADE your present laundry department or insure your new laundry will turn out the highest quality linens at the lowest possible cost.



Flatwork ironing and automatic folding is now combined in a single unit to save you space and money while providing SUPERIOR quality to your dining room and room linens. And all at a cost lower than you could ever expect.

The **FINISH MASTER** combination will save you more than 15% in purchase price and 40% in floor space over comparable capacity separate ironer and folder.

All of the latest available technology has been utilized in the design and construction of this machine to insure safety, extended operating life and economical operation.

The unique feature of allowing finished and folded work to be delivered either back to the feeding operators or returned to the rear of the machine, where an additional operator is positioned, makes this machine the most versatile in the industry.

There are no dials to turn or switches to set for items of different size. Simply feed the work to the machine and the neatly finished items will be accurately folded to a width of approximately 18" and delivered for final cross folding and stacking.

Small items, such as napkins and pillowcases will automatically by-pass the folding operation and are delivered for stacking or future folding.

Ideally suited to handle the laundry flatwork requirements of hotels ranging from 95 to 325 rooms, and hospitals from 59 to 198 beds, the versatility of this machine is unequalled by any other combination of/or separate machines.

# It took Sharper Finish to design and build the First and Only Combination Laundry Flatwork Ironer and Automatic Folder that makes sense and works well too.

Feed the flatwork to be finished in the front of the machine and receive beautifully ironed and folded work back at the front.

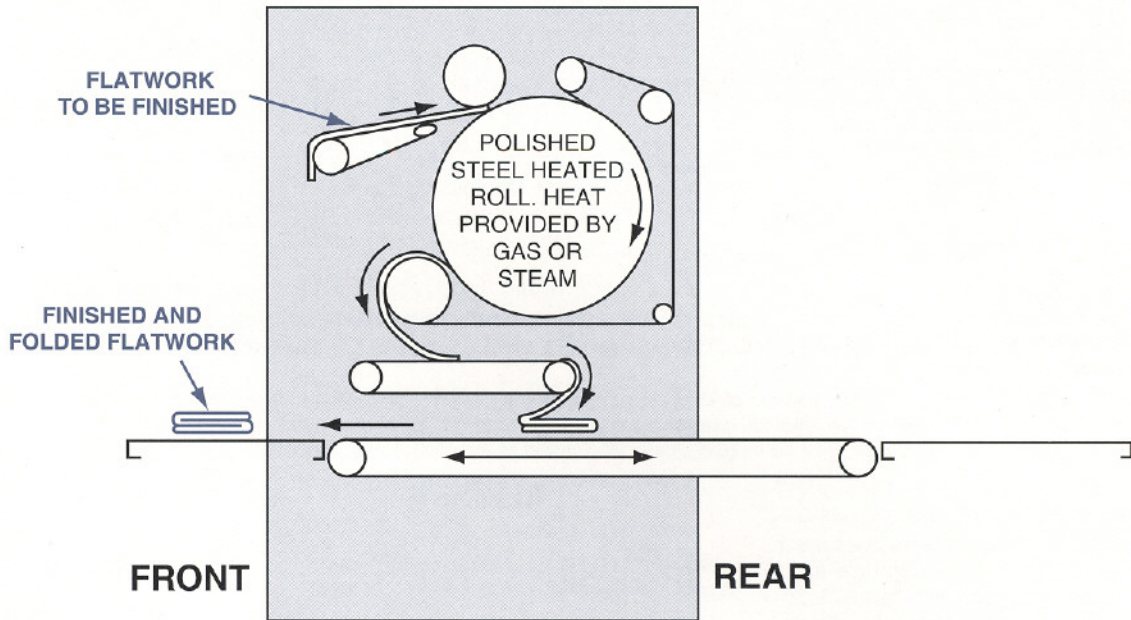

**OR** Feed the flatwork to be finished in the front of the machine and receive beautifully ironed and folded work at the rear of the machine, to more than double the production.

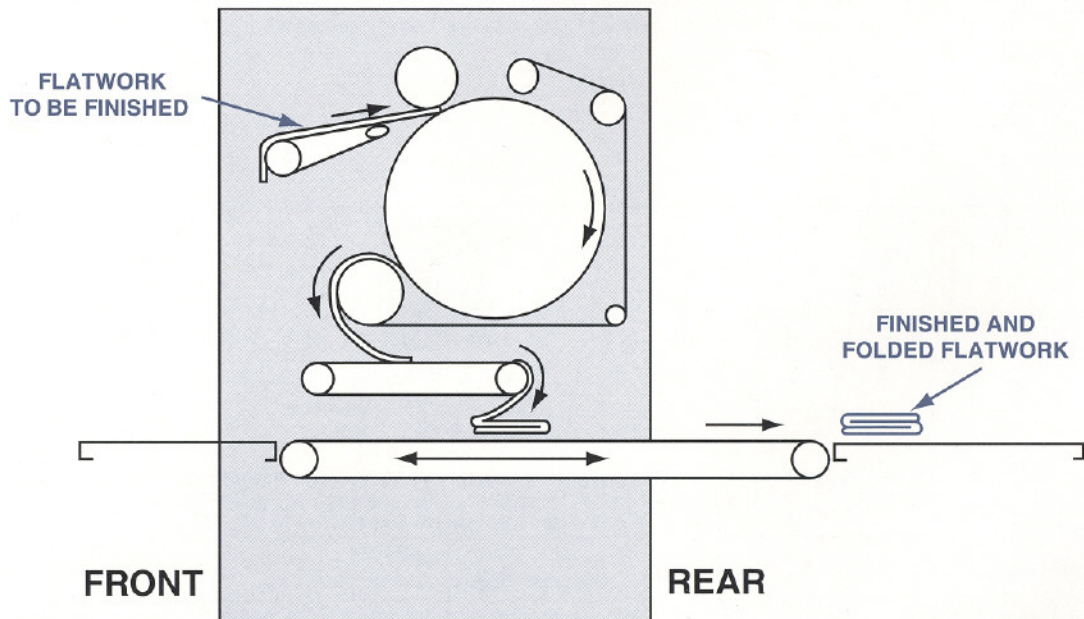

All with the flip of a switch.

# FINISH MASTER **2000** with Built-In AccuFold®

FLATWORK FINISHER

## PRODUCTION DATA

	FRONT FEED REAR DELIVERY WITH 3 OPERATORS	FRONT FEED FRONT DELIVERY WITH 2 OPERATORS
<b>MAXIMUM THEORETICAL CAPACITY</b>	575 pounds per hour of finished flatwork	
<b>AVERAGE CAPACITY</b> - Sheets per hour	300	120
<b>INSTITUTIONAL FLATWORK</b> Pounds per hour ① ②	300	125
<b>MAXIMUM NUMBER OF HOTEL ROOMS FOR WHICH FLATWORK CAN BE PROCESSED ③</b>		
5 days (40 hours) per week	235	95
6 days (48 hours) per week	280	112
7 days (56 hours) per week	325	132
<b>MAXIMUM NUMBER OF HOSPITAL BEDS FOR WHICH FLATWORK CAN BE PROCESSED ③</b>		
5 days (40 hours) per week	143	59
6 days (48 hours) per week	171	70
7 days (56 hours) per week	198	81

① Pounds of institutional flatwork per hour is based on 65% large items such as sheets and 35% medium and small items such as tableclothes, napkins and pillowcases.

② An efficiency rate of 65% is applied to large items, such as sheets, and 35% to medium and small items such as tableclothes, napkins and pillowcases.

③ Predicated on total average linen usage of 11 lbs. per hotel/motel room per day, and an average of 18 lbs. per hospital bed per day.

## DETERMINING FLATWORK FINISHING REQUIREMENTS

A simple formula can be used to determine total laundry and flatwork finishing requirements.

**EXAMPLE: A 225 room hotel or motel using 11 pounds of linen per day and operating a laundry 40 hours per week:**

$$\begin{array}{ccccccccccc}
 11 & \times & 225 & = & 2,475 & \times & 7 & = & 17,325 & \div & 40 & = & 433 & \times & 65\%^* & = & 282 \\
 \text{POUNDS} & & \text{NUMBER} & & \text{TOTAL} & & \text{NUMBER} & & \text{TOTAL} & & \text{NUMBER} & & \text{TOTAL} & & \text{\% OF} & & \text{TOTAL} \\
 \text{PER ROOM} & & \text{OF ROOMS} & & \text{POUNDS} & & \text{OF DAYS} & & \text{POUNDS} & & \text{OF HOURS} & & \text{POUNDS} & & \text{FLATWORK} & & \text{POUNDS OF} \\
 & & & & \text{PER DAY} & & \text{ACCUMULATION} & & \text{PER WEEK} & & \text{LAUNDRY IS} & & \text{PER HOUR} & & \text{CONTAINED} & & \text{FLATWORK} \\
 & & & & & & & & & & \text{OPERATED} & & & & \text{IN TOTAL} & & \text{TO BE} \\
 & & & & & & & & & & \text{PER WEEK} & & & & & & \text{FINISHED} \\
 & & & & & & & & & & & & & & & & \text{PER HOUR}
 \end{array}$$

\*Studies show that approximately 65% of total will be flatwork, 30% can be tumble dried and 5% will be miscellaneous.

To determine your specific needs, just complete the following formula, inserting your own quantities and working hours.

$$\begin{array}{ccccccccccc}
 \underline{\hspace{1cm}} & \times & \underline{\hspace{1cm}} & = & \underline{\hspace{1cm}} & \times & \underline{\hspace{1cm}} & = & \underline{\hspace{1cm}} & \div & \underline{\hspace{1cm}} & = & \underline{\hspace{1cm}} & \times & \underline{\hspace{1cm}} & = & \underline{\hspace{1cm}} \\
 \text{POUNDS} & & \text{NUMBER} & & \text{TOTAL} & & \text{NUMBER} & & \text{TOTAL} & & \text{NUMBER} & & \text{TOTAL} & & \text{\% OF} & & \text{TOTAL} \\
 \text{PER ROOM} & & \text{OF ROOMS} & & \text{POUNDS} & & \text{OF DAYS} & & \text{POUNDS} & & \text{OF HOURS} & & \text{POUNDS} & & \text{FLATWORK} & & \text{POUNDS OF} \\
 & & & & \text{PER DAY} & & \text{ACCUMULATION} & & \text{PER WEEK} & & \text{LAUNDRY IS} & & \text{PER HOUR} & & \text{CONTAINED} & & \text{FLATWORK} \\
 & & & & & & & & & & \text{OPERATED} & & & & \text{IN TOTAL} & & \text{TO BE} \\
 & & & & & & & & & & \text{PER WEEK} & & & & & & \text{FINISHED} \\
 & & & & & & & & & & & & & & & & \text{PER HOUR}
 \end{array}$$

Production capacity of a well designed and manufactured flatwork ironer is governed by many factors which in most cases are beyond the control of the machine manufacturer. Only years of experience in the manufacturing of this type of machinery and extensive actual hands on working knowledge enables us at Sharper Finish to provide you with realistic, obtainable production data.

In preparing these production figures we have had to

assume that certain conditions exist that are consistent with a well managed on premise laundry.

Our assumptions are as follows:

1. Flatwork to be processed is blended materials containing 50% synthetic and 50% natural fibres.
2. Moisture content of work to be processed will not exceed 25% and residual moisture content will not exceed 4%.

# FINISH MASTER **2000** with Built-In AccuFold®

FLATWORK FINISHER

## SPECIFICATIONS

### SAFETY FEATURES

Bright red safety finger guard extends full width of finishing surface and stops machine if touched by operator. Main start button must be pressed before machine can be restarted.

Safety cable extends across entire feeding surface and across entire receiving surface on rear discharge machines. Moving this cable in any direction stops machine at once.

Access panels provided with safety switch to prevent panel being opened while machine is in operation and to insure panel is in place during normal operation.

Sturdy Guards provided at front and rear of machine to prevent contact with moving items.

All operating controls conveniently located at front of machine.

Ventilating canopy provided with properly sized motor and blower to insure removal of moisture created during the finishing process. Airflow switch is located in the air stream to insure correct airflow before heating system can be started. (Gas heated models.)

All motors equipped with magnetic starting devices and overload protection.

Safety operating and maintenance instructions conveniently displayed on the machine in both English and Spanish.

### FINISHING SURFACE

120" (3048 mm).

### FRAMES

All steel-welded construction.

### HEATED ROLL

All steel accurately formed, ground, and polished to mirror like finish.

### HEATING

Equipped with full-length multi port burner for even heat distribution and maximum efficiency. Pilotless ignition system saves energy while providing safe operation.

Steam heated model is virtually maintenance free as energy to heat this machine is provided by outside source.

### HEAT CONTROL

Extremely accurate snap action thermostat insures accurate control of all types of work. (Gas heated models).

### PRESSING ROLL

Constructed from heavy gauge seamless steel tubing.

### FINISHING PRESSURE

Pressure automatically controlled by heavy tension springs. Pressure adjustable to compensate for padding variations.

### PADDING

Heat resistant pad and cover cloth is provided to produce a fine finish and a longer life.

### AUTOMATIC FEEDING DEVICE

Work to be finished is simply placed on automatic conveyor, which takes it to heated and pressing area for neat, fast finishing.

### RECEIVING TABLE

Convenient receiving tables allow finished work to be removed at either front or rear of machine.

### DRIVE

Totally variable speed drive is accomplished with time tested and proven mechanical components. Energy efficient ball bearing motor powers gear reduction unit. Conveniently located knob allows any operating speed between 25 and 75 feet per minute (7.6-23 m/min.).

### BEARINGS

All rolls mounted in oversize ball bearings.

### ELECTRICAL CONTROLS

All control circuits operate on 24 volts to insure operator safety. Magnetic contactor provided for control of motor. Drive motor thermally protected.

### FINISH

Entire machine is finished with high-grade machine enamel in your choice of colors.

Safety finger guard is finished in bright red. Feed and receiving tables are finished in white enamel to produce a finely trimmed machine.

### INTELATROL

Automatic Energy Saver System Standard on all gas and electrically heated machines.

## TECHNICAL DATA

MACHINE MODEL	FINISHING SURFACE WIDTH INCHES (mm)	HEATED ROLL DIAMETER INCHES (mm)	INFINITELY VARIABLE SPEED RANGE FEET PER MINUTE (m / MM)	ELECTRICAL REQUIREMENTS WITH CANOPY MOTOR H.P. (KW)	MAXIMUM GAS INPUT B.T.U. / HR. (KW)	GAS INLET - INCHES	STEAM CONSUMPTION BOILER H.P. (kg. / hr.)	STEAM INLET - INCHES	CONDENSATE RETURN - INCHES	MAXIMUM STEAM PRESSURE P.S.I. (BAR)	COMPRESSED AIR INLET - INCHES	FREE AIR CONSUMPTION 50 P.S.I. (3.4 ATU)	NET WEIGHT POUNDS (kg)	DOMESTIC CRATED WEIGHT POUNDS (kg)	DOMESTIC CRATED SIZE L x W x H INCHES (mm)	DOMESTIC CRATED VOLUME CUBIC FEET (m <sup>3</sup> )	EXPORT CRATED WEIGHT POUNDS (kg)	EXPORT CRATED SIZE L x W x H INCHES (mm)	EXPORT CRATED VOLUME CUBIC FEET (m <sup>3</sup> )
G / AF GAS HEATED	120 (3050)	20 (508)	20-60 (6.1-18.3)	3/4 + 1 (.559 + .746)	220,000 (64.5)	3/4	-	-	-	1/4	1.5 cu. ft. (.04 m <sup>3</sup> )	3290 (1492)	3755 (1703)	170 1/2 x 49 1/2 x 78 1/2 (4431 x 1257 x 1994)	383 (10.9)	3985 (1808)	171 x 48 x 78 1/2 (4343 x 1219 x 1994)	373 (10.6)	
S / AF STEAM HEATED	120 (3050)	20 (508)	20-60 (6.1-18.3)	3/4 + 1 (.559 + .746)	-	-	4.25 (66)	1	3/4	150 (10)	1/4	1.5 cu. ft. (.04 m <sup>3</sup> )	3645 (1653)	4100 (1860)	170 1/2 x 49 1/2 x 78 1/2 (4431 x 1257 x 1994)	383 (10.9)	4330 (1964)	171 x 48 x 78 1/2 (4343 x 1219 x 1994)	373 (10.6)

In keeping with our policy of continuous improvement, Sharper Finish, Inc. reserves the right to make changes in design or specifications without notification or obligation.

# DIMENSIONS

INCHES  
(mm)

\*CANOPY DISCHARGE CONNECTION 11 3/4" x 5 7/8" (298mm x 149mm) 1050 C.F.M. AT 2" S.P. 10" (254 mm) ROUND DISCHARGE PIPING MAY BE USED. VENT MUST BE INDEPENDENTLY DISCHARGED TO ATMOSPHERE. DO NOT INTERCONNECT WITH OTHER VENT LINES.

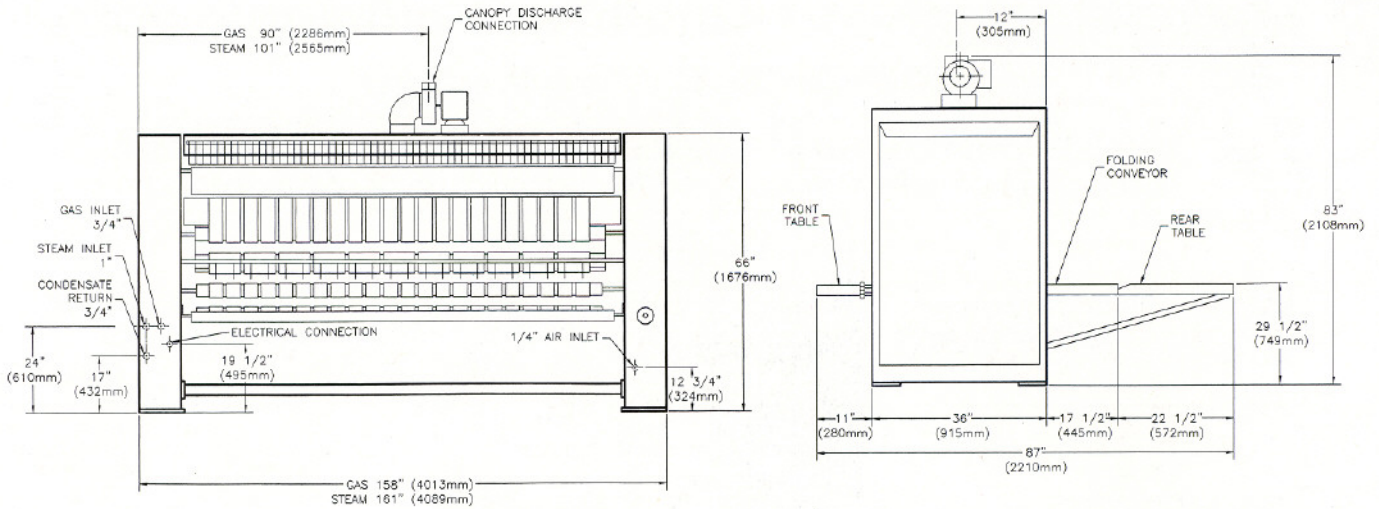

**ALL UTILITY CONNECTIONS AT REAR OF MACHINE.  
DO NO USE FOR CONSTRUCTION PURPOSES UNLESS CERTIFIED CORRECT BY SHARPER FINISH, INC.**

Allow minimum of 18" (457 mm) clearance at ends of machine for maintenance access.  
Provide adequate make-up air according to current local requirements.  
Canopy vent must be independently discharged to atmosphere. Do not interconnect with other vent lines.

Distributed by:



ETL LISTED



Sharper Finish, Inc.  
4500 Augusta Boulevard  
Chicago, IL 60651 U.S.A.

USA Sales Office: Entire USA Call 800-247-4766 or 773-276-4800 • Fax 800-247-4428 or 773-276-6878  
International Sales Office: Entire USA and Canada Call 800-474-7346  
Outside USA and Canada Call 915-532-1926 • Fax 915-532-8373

Form No. SF5124

Copyright 1999 by Sharper Finish, Inc.

In view of Sharper Finish's policy of providing you with the best products possible, we reserve the right to change product specifications and appearance without notice. Contact the sales department for exact specifications, dimensions, and product approvals. Sharper Finish has manufactured flatwork finishing equipment since 1911. We are now one of the leading world manufacturers exporting over 60% of our production. We actively market our products in 92 countries and have over 175 authorized distributors worldwide.